

GRENDIA ES

Diesel and LPG Counterbalance
4 Wheel Pneumatic Tyres • 1.5 – 3.5 tonnes

FD/FG15N
FD/FG18N
FD/FG20CN
FD/FG20N
FD/FG25N
FD/FG30N
FD/FG35N

Outstanding performance... exceptional economy

Developed to help your operator achieve maximum productivity, while minimising running costs, GRENDIA ES sets the highest standards for IC engine counterbalance forklift trucks. With its exceptional fuel economy, durable components and low-maintenance design, GRENDIA makes perfect business sense. What's more, it comes with a package of advanced features, fitted as standard, that offers true value for money.

The name GRENDIA means 'Green Diamond': green for environmental protection; diamond for high quality, reliability and sound investments.

Fast, stable and exceptionally powerful, GRENDIA forklift trucks offer a potent combination of high efficiency, low emissions and very low noise levels.

To that, Mitsubishi has added a host of ergonomic features to maximise comfort, control and precision. The result is a forklift that can be relied upon to deliver top performance, whatever the application, whatever the conditions.

Frame and body

- **Robust construction** has been designed and rigorously tested to ensure high stability, rigidity and protection.
- **Full belly guard construction** protects engine compartment from any ingress – including dirt, dust and water – for long engine life.
- **Compact design** allows for reduced aisle dimensions, ensuring cost-effective operations.

Mast and fork assembly

- **Heavy-duty clear-view mast** offers market-leading vision of fork tip and load, for faster cycle times and reduced damage.
- **New bearing High-strength carriage** features six bearings, allowing for quicker load handling.

Drive

- **Advanced diesel technology** lowers fuel consumption and ensures complete, clean burning – as well as low noise levels.
- **Three-way catalytic converter** – fitted as standard – significantly reduces exhaust emissions to one of the industry's lowest levels. (LPG models only.)
- **Advanced speed control** – as standard – restricts speed while still maintaining full power on ramps.
- **Engine management controller** allows for simultaneous, multiple engine and electronic functions, resulting in industry-leading fuel consumption and lower emissions.



FD15-35N Models

Diesel Counterbalance • 4 Wheel Pneumatic Tyres • 1.5 – 3.5 tonnes

Characteristics						
1.01	Manufacturer (abbreviation)			Mitsubishi	Mitsubishi	Mitsubishi
1.02	Manufacturer's model designation			FD15N	FD18N	FD20CN
1.03	Power source: (battery, diesel, LPG, petrol)			Diesel	Diesel	Diesel
1.04	Operator type: pedestrian, (operator)-standing, -seated			Seated	Seated	Seated
1.05	Load capacity	Q	kg	1500	1750	2000
1.06	Load centre distance	c	(mm)	500	500	500
1.08	Load distance, axle to fork face	x	(mm)	400	400	415
1.09	Wheelbase	y	(mm)	1400	1400	1400
Weight						
2.01	Truck weight, without load / including battery (simplex mast, lowest lift height)		kg	2530	2720	3030
2.02	Axle loading with maximum load, front / rear (simplex mast, lowest lift height)		kg	3520 / 510	3880 / 590	4330 / 700
2.03	Axle loading without load, front / rear (simplex mast, lowest lift height)		kg	1060 / 1470	1000 / 1720	1020 / 2010
Wheels, Drive Train						
3.01	Tyres: V=solid, L=pneumatic, SE=solid pneumatic - front / rear			SE / SE	SE / SE	SE / SE
3.02	Tyre dimensions, front			6.50 - 10 - 10	6.50 - 10 - 10	6.50 - 10 - 5
3.03	Tyre dimensions, rear			5.00 - 8 - 8	5.00 - 8 - 8	5.00 - 8 - 3
3.05	Number of wheels, front / rear (x=driven)			2x / 2	2x / 2	2x / 2
3.06	Track width (centre of tyres), front	b10	(mm)	890	890	890
3.07	Track width (centre of tyres), rear	b11	(mm)	900	900	900
Dimensions						
4.01	Mast tilt, forwards / backwards	α/β	°	6 / 10	6 / 10	6 / 10
4.02	Height with mast lowered (see tables)	h1	(mm)	1990	1990	1990
4.03	Free lift (see tables)	h2	(mm)	80	80	80
4.04	Lift height (see tables)	h3	(mm)	3000	3000	3000
4.05	Overall height with mast raised	h4	(mm)	4055	4055	4055
4.07	Height to top of overhead guard	h6	(mm)	2140	2140	2140
4.08	Seat height	h7	(mm)	930	930	930
4.12	Tow coupling height	h10	(mm)	290	290	290
4.19	Overall length	l1	(mm)	3180	3220	3275
4.20	Length to fork face (includes fork thickness)	l2	(mm)	2260	2300	2355
4.21	Overall width	b1 / b2	(mm)	1065 / -	1065 / -	1065 / -
4.22	Fork dimensions (thickness, width, length)	s / e / l	(mm)	35x100x920	35x100x920	35x100x920
4.23	Fork carriage to DIN 15 173 A / B / no			2A	2A	2A
4.24	Fork carriage width	b3	(mm)	920	920	920
4.31	Ground clearance under mast, with load	m1	(mm)	110	110	110
4.32	Ground clearance at centre of wheelbase, with load (forks lowered)	m2	(mm)	135	135	135
4.33	Working aisle width with 1000 x1200 mm pallets, crosswise	Ast	(mm)	3550	3580	3635
4.34	Working aisle width with 800 x1200 mm pallets, crosswise	Ast	(mm)	3350	3380	3435
4.35	Turning circle radius	Wa	(mm)	1950	1980	2020
4.36	Minimum distance between centers of rotation	b13	(mm)	555	555	550
Performance						
5.01	Travel speed, with / without load		km/h	19 / 19.5	19 / 19.5	19 / 19.5
5.02	Lifting speed, with / without load		m/s	0.60 / 0.65	0.60 / 0.65	0.60 / 0.65
5.03	Lowering speed, with / without load		m/s	0.52 / 0.50	0.52 / 0.50	0.52 / 0.50
5.05	Rated drawbar pull, with / without load		N	11900 / 11500	11700 / 11500	11400 / 11500
5.07	Gradeability, with / without load		%	31 / 52	27 / 47	24 / 41
5.10	Service brakes (mechanical / hydraulic / electric / pneumatic)			hydraulic	hydraulic	hydraulic
I.C. Engine						
7.01	Manufacturer / Type			S4Q2	S4Q2	S4Q2
7.02	Rated output to ISO 1585		kW	28	28	28
7.03	Rated speed to DIN 70 020		rpm	2500	2500	2500
7.04	Number of cylinders / cubic capacity		/cm ³	4 / 2505	4 / 2505	4 / 2505
Miscellaneous						
8.01	Type of drive control			Powershift / 1	Powershift / 1	Powershift / 1
8.02	Operating pressure for attachments		bar	180	180	180
8.03	Oil flow for attachments		l/min	62	62	62
8.05	Towing coupling design / DIN type, ref.			Pin	Pin	Pin

NOTE: the (lower) nett power specified on engine label according to EU regulations

S4S = 35.3 kW nett power

S4Q2 = 28 kW nett power

GRENDIA THE GREEN DIAMOND

The green colour of our trucks is a sign of our commitment to protecting the environment.

The diamond shapes in our logo are a reminder that – like a diamond – a Mitsubishi forklift truck guarantees quality, reliability and a sound investment.

	Mitsubishi	Mitsubishi	Mitsubishi	Mitsubishi
	FD20N	FD25N	FD30N	FD35N
	Diesel	Diesel	Diesel	Diesel
	Seated	Seated	Seated	Seated
	2000	2500	3000	3500
	500	500	500	500
	455	460	495	495
	1600	1600	1700	1700
	3380	3680	4350	4740
	4640 / 740	5430 / 750	6510 / 840	7220 / 1020
	1450 / 1930	1430 / 2250	1750 / 2600	1670 / 3070
	SE / SE	SE / SE	SE / SE	SE / SE
	7.00 - 12-12	7.00 - 12 - 12	28x9 - 15 - 12	250 - 15 - 12
	6.00 - 9 - 8	6.00 - 9 - 10	6.50 - 10 - 10	6.50 - 10 - 12
	2x / 2	2x / 2	2x / 2	
	960	960	1060	1060
	980	980	980	980
	6 / 10	6 / 10	6 / 10	6 / 10
	1990	1990	2015	2130
	100	100	95	95
	3000	3000	3000	3000
	4055	4055	4055	4055
	2145	2145	2165	2175
	940	940	990	990
	310	310	330	340
	3405	3480	3805	3865
	2485	2560	2735	2795
	1150 / 1640	1150 / 1640	1275/1690	1290/1690
	45 x 100 x 920	45 x 100 x 920	45 x 122 x 1070	45 x 122 x 1070
	2A	2A	3A	3A
	1000	1000	1000	1000
	115	115	135	150
	135	135	165	170
	3855	3885	4070	4130
	3655	3685	3870	3930
	2200	2230	2380	2440
	715	715	780	780
	19 / 19.5	19 / 19.5	19 / 19.5	19 / 19.5
	0.64 / 0.67	0.64 / 0.67	0.51 / 0.54	0.43 / 0.46
	0.50 / 0.50	0.50 / 0.50	0.53 / 0.50	0.42 / 0.40
	17200 / 16700	17100 / 16600	17500 / 17300	15900 / 16000
	34 / 57 hydraulic	29 / 51 hydraulic	25 / 45 hydraulic	20 / 36 hydraulic
	S4S	S4S	S4S	S4S
	35.3	35.3	35.3	35.3
	2250	2250	2250	2250
	4 / 3331	4 / 3331	4 / 3331	4 / 3331
	Powershift / 1	Powershift / 1	Powershift / 1	Powershift / 1
	180	180	180	180
	75	75	73	73
	Pin	Pin	Pin	Pin

Continuing improvement may lead to changes in these specifications.



Auto-style controls

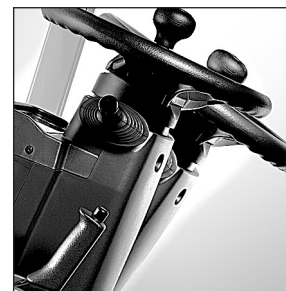

Adjustable steering column



Cowl-mounted levers



Stylish, robust construction

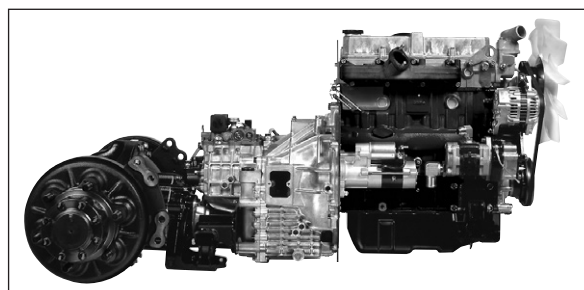

Fully floating powertrain



FG15-35N Models

LPG Counterbalance • 4 Wheel Pneumatic Tyres • 1.5 – 3.5 tonnes

Characteristics						
1.01	Manufacturer (abbreviation)			Mitsubishi	Mitsubishi	Mitsubishi
1.02	Manufacturer's model designation			FG15N	FG18N	FG20CN
1.03	Power source: (battery, diesel, LP gas, petrol)			LPG	LPG	LPG
1.04	Operator type: pedestrian, (operator)-standing, -seated			Seated	Seated	Seated
1.05	Load capacity	Q	kg	1500	1750	2000
1.06	Load centre distance	c	(mm)	500	500	500
1.08	Load distance, axle to fork face	x	(mm)	400	400	415
1.09	Wheelbase	y	(mm)	1400	1400	1400
Weight						
2.01	Truck weight, without load / including battery (simplex mast, lowest lift height)		kg	2470	2660	2980
2.02	Axle loading with maximum load, front / rear (simplex mast, lowest lift height)		kg	3510 / 460	3870 / 540	4320 / 660
2.03	Axle loading without load, front / rear (simplex mast, lowest lift height)		kg	1040 / 1430	990 / 1670	1010 / 1970
Wheels, Drive Train						
3.01	Tyres: V=solid, L=pneumatic, SE=solid pneumatic - front / rear			SE / SE	SE / SE	SE / SE
3.02	Tyre dimensions, front			6.50 - 10 - 10	6.50 - 10 - 10	6.50 - 10 - 5
3.03	Tyre dimensions, rear			5.00 - 8 - 8	5.00 - 8 - 8	5.00 - 8 - 3
3.05	Number of wheels, front / rear (x=driven)			2x / 2	2x / 2	2x / 2
3.06	Track width (centre of tyres), front	b10	(mm)	890	890	890
3.07	Track width (centre of tyres), rear	b11	(mm)	900	900	900
Dimensions						
4.01	Mast tilt, forwards / backwards	a/b	°	6 / 10	6 / 10	6 / 10
4.02	Height with mast lowered (see tables)	h1	(mm)	1990	1990	1990
4.03	Free lift (see tables)	h2	(mm)	80	80	80
4.04	Lift height (see tables)	h3	(mm)	3000	3000	3000
4.05	Overall height with mast raised	h4	(mm)	4055	4055	4055
4.07	Height to top of overhead guard	h6	(mm)	2140	2140	2140
4.08	Seat height	h7	(mm)	930	930	930
4.12	Tow coupling height	h10	(mm)	290	290	290
4.19	Overall length	l1	(mm)	3180	3220	3275
4.20	Length to fork face (includes fork thickness)	l2	(mm)	2260	2300	2355
4.21	Overall width	b1/b2	(mm)	1065 / -	1065 / -	1065 / -
4.22	Fork dimensions (thickness, width, length)	s / e / l	(mm)	35x100x920	35x100x920	35x100x920
4.23	Fork carriage to DIN 15 173 A / B / no			2A	2A	2A
4.24	Fork carriage width	b3	(mm)	920	920	920
4.31	Ground clearance under mast, with load	m1	(mm)	110	110	110
4.32	Ground clearance at centre of wheelbase, with load (forks lowered)	m2	(mm)	135	135	135
4.33	Working aisle width with 1000 x1200 mm pallets, crosswise	Ast	(mm)	3550	3580	3635
4.34	Working aisle width with 800 x1200 mm pallets, crosswise	Ast	(mm)	3350	3380	3435
4.35	Turning circle radius	Wa	(mm)	1950	1980	2020
4.36	Minimum distance between centers of rotation	b13	(mm)	555	555	555
Performance						
5.01	Travel speed, with / without load		km/h	18.5 / 19.5	18 / 19.5	18 / 19.5
5.02	Lifting speed, with / without load		m/s	0.64 / 0.65	0.64 / 0.65	0.64 / 0.65
5.03	Lowering speed, with / without load		m/s	0.52 / 0.50	0.52 / 0.50	0.52 / 0.50
5.05	Rated drawbar pull, with / without load		N	17100 / 16800	17000 / 16700	17000 / 16600
5.07	Gradeability, with / without load		%	48 / 91	42 / 79	37 / 69
5.10	Service brakes (mechanical / hydraulic / electric / pneumatic)			hydraulic	hydraulic	hydraulic
I.C. Engine						
7.01	Manufacturer / Type			GCT GK21E	GCT GK21E	GCT GK21E
7.02	Rated output to ISO 1585		kW	41	41	41
7.03	Rated speed to DIN 70 020		rpm	2700	2700	2700
7.04	Number of cylinders / cubic capacity		/cm ³	4 / 2065	4 / 2065	4 / 2065
Miscellaneous						
8.01	Type of drive control			Powershift / 1	Powershift / 1	Powershift / 1
8.02	Operating pressure for attachments		bar	180	180	180
8.03	Oil flow for attachments		l/min	60	60	60
8.05	Towing coupling design / DIN type, ref.			PIN	PIN	PIN

NOTE: the (lower) nett power specified on engine label according to EU regulations

S4S = 35.3 kW nett power

S4Q2 = 28 kW nett power

	Mitsubishi	Mitsubishi	Mitsubishi	Mitsubishi
	FG20N	FG25N	FG30N	FG35N
	LPG	LPG	LPG	LPG
	Seated	Seated	Seated	Seated
	2000	2500	3000	3500
	500	500	500	500
	455	460	495	495
	1600	1600	1700	1700
	3270	3570	4240	4630
	4600 / 670	5390 / 680	6470 / 770	7180 / 950
	1410 / 1860	1390 / 2180	1710 / 2530	1630 / 3000
	SE / SE	SE / SE	SE / SE	SE / SE
	7.00 - 12 - 12	7.00 - 12 - 12	28x9 - 15 - 12	250 - 15 - 12
	6.00 - 9 - 8	6.00 - 9 - 10	6.50 - 10 - 10	6.50 - 10 - 12
	2x / 2	2x / 2	2x / 2	2x / 2
	960	960	1060	1060
	980	980	980	980
	6 / 10	6 / 10	6 / 10	6 / 10
	1990	1990	2015	2015
	100	100	95	95
	3000	3000	3000	3000
	4055	4055	4055	4055
	2145	2145	2165	2175
	940	940	990	990
	310	310	330	340
	3405	3480	3805	3865
	2485	2560	2735	2795
	1150 / 1640	1150 / 1640	1275 / 1690	1290 / 1690
	45 x 100 x 920	45 x 100 x 920	45 x 122 x 1070	45 x 122 x 1070
	2A	2A	3A	3A
	1000	1000	1000	1000
	115	115	135	150
	135	135	165	170
	3855	3885	4070	4130
	3655	3685	3870	3930
	2200	2230	2380	2440
	715	715	780	780
	18 / 19	18 / 19	19 / 19.5	19 / 19.5
	0.59 / 0.61	0.59 / 0.61	0.52 / 0.53	0.43 / 0.44
	0.50 / 0.50	0.50 / 0.50	0.53 / 0.50	0.42 / 0.40
	17000 / 16900	16800 / 16800	20900 / 20600	19100 / 19100
	34 / 59 hydraulic	29 / 52 hydraulic	31 / 57 hydraulic	25 / 46 hydraulic
	GCT GK21E	GCT GK21E	GCT GK25E	GCT GK25E
	41	41	46.9	46.9
	2700	2700	2700	2700
	4 / 2065	4 / 2065	4 / 2488	4 / 2488
	Powershift / 1	Powershift / 1	Powershift / 1	Powershift / 1
	180	180	180	180
	68	68	73	73
	PIN	PIN	PIN	PIN

Continuing improvement may lead to changes in these specifications.



Powerful diesel and LPG engines



Clear-view overhead guard



GRENDIA - setting highest standards



LED lights (now standard)



Auto-style pedals



Fingertip hydraulic controls (optional)

GRENDIA

THE GREEN DIAMOND

The green colour of our trucks is a sign of our commitment to protecting the environment.

The diamond shapes in our logo are a reminder that – like a diamond – a Mitsubishi forklift truck guarantees quality, reliability and a sound investment.

FD/FG15-20(C)N Models

Mast Performance and Capacity

Mast type	FD/FG15N-18N FD/FG20CN			FD/FG15N		FD/FG18N		FD/FG20CN	
	h3 mm	h1 mm	h4 mm	h2/h5 mm	Q @ c=500mm kg	h2/h5 mm	Q @ c=500mm kg	h2/h5 mm	Q @ c=500mm kg
Simplex	3000	1990	4055	80 -	1500	80 -	1750	80 -	2000
	3300	2140	4355	80 -	1500	80 -	1750	80 -	2000
	3500	2240	4555	80 -	1500	80 -	1750	80 -	2000
	3700	2340	4755	80 -	1500	80 -	1750	80 -	2000
	4000	2540	5055	80 -	1500	80 -	1750	80 -	1950
	4500	2790	5555	80 -	1425	80 -	1700	80 -	1400
	5000	3050	6055	80 -	1375	80 -	1600*	-	-
	5500	3300	6555	80 -	1250*	80 -	1525*	-	-
6000	3550	7055	80 -	1200*	80 -	1325*	-	-	
Duplex	3000	1995	4055	- 940	1500	- 940	1750	- 940	2000
	3290	2140	4350	- 1085	1500	- 1085	1750	- 1085	2000
	3510	2260	4570	- 1205	1500	- 1205	1750	- 1205	2000
	4030	2585	5085	- 1530	1500	- 1530	1750	- 1530	2000
Triplex	3700	1790	4755	- 735	1500	- 735	1750	- 735	2000
	4000	1890	5055	- 835	1475	- 835	1750	- 835	2000
	4300	1990	5355	- 935	1425	- 935	1700	- 935	1950
	4700	2140	5755	- 1085	1375	- 1085	1625*	- 1085	1900
	5000	2240	6055	- 1185	1325	- 1185	1575*	- 1185	1325
	5500	2430	6555	- 1375	1250*	- 1375	1500*	-	-
	6000	2610	7055	- 1555	1175*	- 1555	1325*	-	-
	6500	2850	7555	- 1759	950	- 1795	950*	-	-
	7000	3050	8055	- 1995	650*	- 1995	650*	-	-

Note: all models with SE tires

Note: * with dual-drive front wheels

See Mast Charts for applicable tilt angle limitations

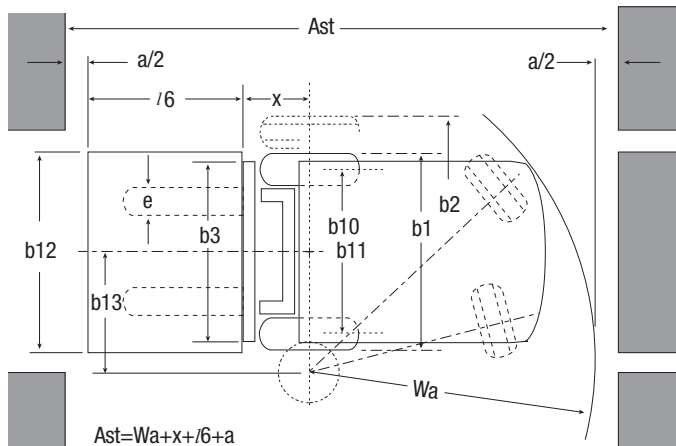
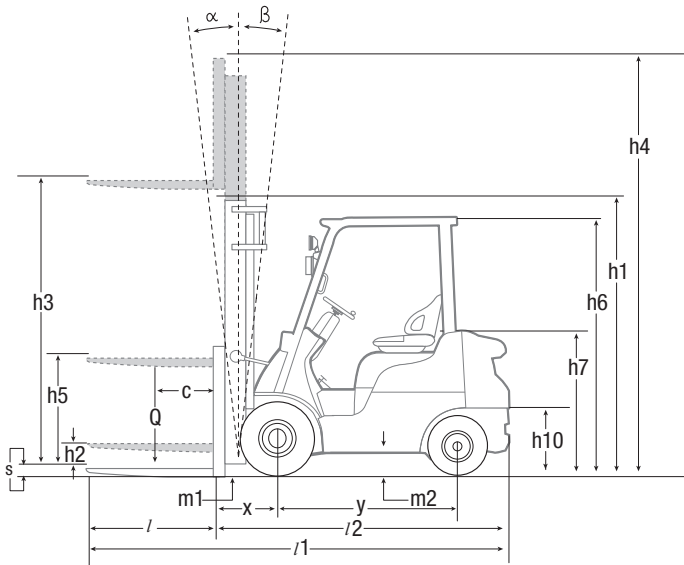

FD/FG20-25N Models

Mast Performance and Capacity

Mast type	FD/FG20N-FD/FG25N			FD/FG20N		FD/FG25N	
	h3 mm	h1 mm	h4 mm	h2/h5 mm	Q @ c=500mm kg	h2/h5 mm	Q @ c=500mm kg
Simplex	3000	1995	4055	100 -	2000	100 -	2500
	3300	2145	4345	100 -	2000	100 -	2500
	3500	2245	4555	100 -	2000	100 -	2000
	3700	2345	4755	100 -	2000	100 -	2500
	4000	2545	5055	100 -	2000	100 -	2500
	4500	2795	5555	100 -	2000	100 -	2500
	5000	3065	6055	100 -	1950	100 -	2400
	5500	3315	6555	100 -	1850*	100 -	2250*
6000	3565	7055	100 -	1800*	100 -	2150*	
Duplex	3000	1995	4055	- 935	2000	- 940	2500
	3300	2145	4350	- 1085	2000	- 1090	2500
	3530	2265	4585	- 1205	2000	- 1210	2500
	4020	2590	5075	- 1530	2000	- 1535	2500
Triplex	3700	1795	4755	- 735	2000	735 -	2500
	4000	1895	5055	- 835	2000	835 -	2500
	4300	1995	5355	- 935	2000	935 -	2500
	4700	2145	5755	- 1085	1950	1085 -	2400
	5000	2245	6055	- 1185	1900	1185 -	2350
	5500	2415	6555	- 1355	1800	1355 -	2200*
	6000	2585	7055	- 1525	1750*	1525 -	2100*
	6500	2795	7555	- 1735	1650*	1735 -	1750*
	7000	3065	8055	- 2005	1250*	2005 -	1250*

- h1 Height with mast lowered
- h2 Standard free lift
- h3 Lift height
- h4 Height with mast raised
- h5 Full free lift
- Q Lifting capacity, rated load
- c Load centre (distance)

- Ast = Working aisle width
- Wa = Turning radius
- a = Safety clearance = 2 x 100 mm
- l6 = Pallet length
- b12 = Pallet width

FD/FG15-20(C)N Models
Capacities at various load centres

Simplex - h3 = 3290 mm

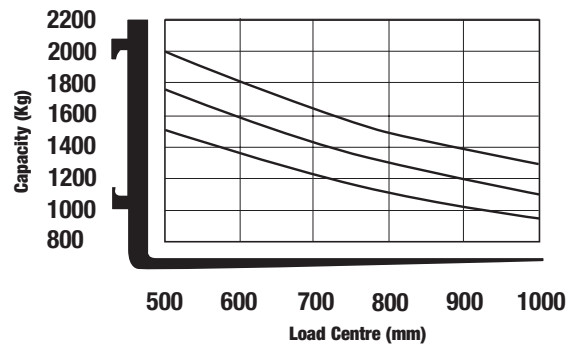

FD/FG30-35N Models

Mast Performance and Capacity

Mast type	FD/FG30N					FD/FG35N				
	h3	h1	h4	h2/h5	Q @ c=500mm	h3	h1	h4	h2/h5	Q @ c=500mm
	mm	mm	mm	mm	kg	mm	mm	mm	mm	kg
Simplex	3000	2015	4055	95 -	3000	3000	2130	4055	95 -	3500
	3300	2165	4355	95 -	3000	3300	2280	4355	95 -	3500
	3500	2265	4555	95 -	3000	3500	2380	4555	95 -	3500
	3700	2365	4755	95 -	3000	3700	2480	4755	95 -	3500
	4000	2565	5055	95 -	3000	4000	2680	5055	95 -	3500
	4500	2815	5555	95 -	3000	4500	2930	5555	95 -	3500
	5000	3115	6055	95 -	2900	5000	3230	6055	95 -	3500
	5500	3365	6555	95 -	2800	5500	3480	6555	95 -	3350
Duplex	3000	2045	4055	- 940	3000	3010	2180	4065	- 1125	3500
	3250	2165	4305	- 1090	3000	3300	2300	4355	- 1245	3500
	3490	2285	4545	- 1210	3000	3500	2445	4555	- 1390	3500
	4010	2610	5065	- 1535	3000	4000	2765	5055	- 1710	3500
Triplex	3700	1815	4755	- 760	3000	3700	1930	4755	- 875	3500
	4000	1915	5055	- 860	3000	4000	2030	5055	- 975	3500
	4300	2015	5355	- 960	3000	4300	2130	5355	- 1075	3500
	4700	2165	5755	- 1110	3000	4700	2280	5755	- 1225	3500
	5000	2265	6055	- 1210	2900	5000	2380	6055	- 1325	3450
	5500	2435	6555	- 1380	2800	5500	2550	6555	- 1495	3300
	6000	2605	7055	- 1550	2700	6000	2720	7055	- 1665	3200
	6500	2815	7555	- 1760	2350	6500	2930	7555	- 1875	2350
7000	3115	8055	- 2060	1600	7000	3230	8055	- 2175	1600	

All dimensions include load backrest. In case load backrest is not used h5 will increase by 390mm (20N, 25N), 350mm (30N), 240mm (35N), while h4 will decrease by 390mm (20N, 25N), 350mm (30N), 240mm (35N). The capacities apply to pneumatic shaped solid tyres (SE).

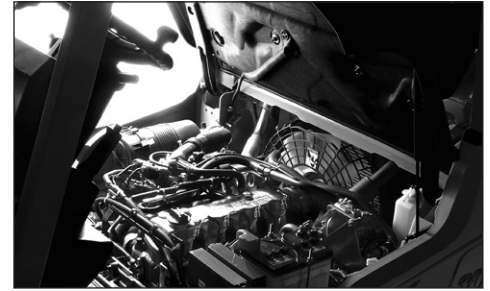

Easy service access

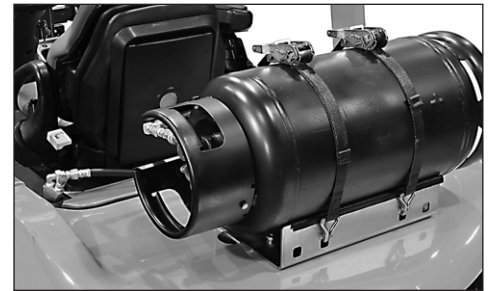

Advanced LPG technology

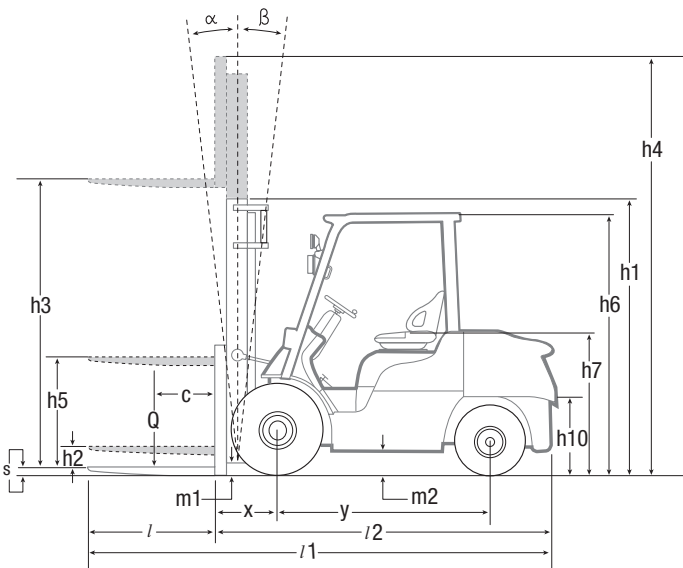

- h1 Height with mast lowered
- h2 Standard free lift
- h3 Lift height
- h4 Height with mast raised
- h5 Full free lift
- Q Lifting capacity, rated load
- c Load centre (distance)

- Ast = Working aisle width
- Wa = Turning radius
- a = Safety clearance = 2 x 100 mm
- l6 = Pallet length
- b12 = Pallet width

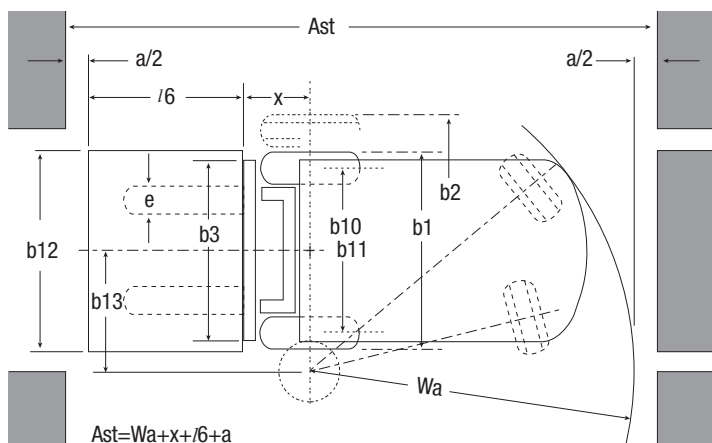

FD/FG20-35N Models
Capacities at various load centres
Simplex - h3 = 3300 mm

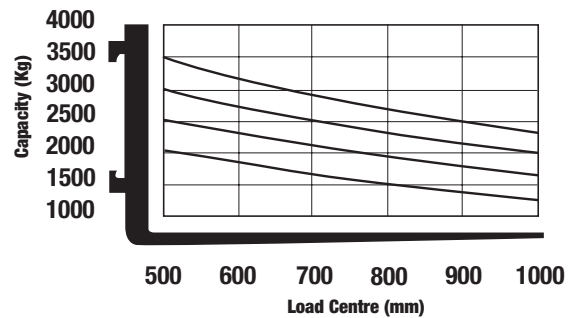



Clear-view mast



Grip/horn for reversing (optional)



Informative LCD display

Steering system

- **Fully hydrostatic steering** is responsive, precise and effortless for the operator and requires little maintenance.
- **Rugged rear axle assembly** with metal bush mounts (instead of competitors' more fragile rubber mounts) is extremely durable.

Brakes

- **Fully hydrostatic drum brakes** give excellent control with little effort and are easy to maintain.

Hydraulics

- **Powerful hydraulic system** offers high residual capacities for comfortable handling of heavier loads.

Electrical and control systems

- **Integrated Presence System (IPS)** prevents all movement of the truck and its mast if the operator is not seated, as well as providing a seatbelt warning light and parking brake alarm.
- **PIN code start-up** with driver-specific settings is included as standard to prevent unauthorised or inappropriate use.

- **Onboard diagnostics** and detailed fault diagnosis via computer connection alerts operators and service engineers to problems, speeds up servicing and prevents damage.
- **LED lights** fitted as standard for 'see-and-be-seen' safety.

Operator compartment and controls

- **All-round visibility** together with ergonomic design and layout of all controls improves comfort, reduces fatigue, increases precision and raises productivity.
- **Fully adjustable, full-suspension seat** with hip restraints and safety belt keeps driver comfortable through the longest of shifts.
- **Automotive-style pedals** with optimum pedal angle are easy to use and give good control without leg strain
- **Adjustable steering column** with memory function helps guarantee optimum driving position, every time.
- **Cowl-mounted hydraulic levers** provide easy-to-reach, easy-to-use control of mast operations.

- **Low noise level at operator's ear** just 78 dBA and low vibration from powertrain increase comfort and reduce fatigue.
- **Clear, informative meter panel** includes essential warning lights and LCD display with speedometer, clock and dual hour meter.

Other features

- **Rapid access features** give quick and easy entry to all areas for checks and servicing.
- **Long service interval** and choice of high-quality components, together with low-maintenance design, minimises downtime and cost of ownership.
- **Sealed wheel arches** together with belly guard significantly reduces dust emitted during operations for clean performance.

Options

- **Fingertip hydraulic controls**
- **Grip/horn button for reversing**
- **Load weight indicator**
- **Speed control**

when
reliability
is **everything**

Like any product bearing the Mitsubishi name, our materials handling equipment benefits from the huge resources and cutting-edge technology of one of the world's largest corporations. So when we promise you **quality, reliability** and **value for money**, you know it's a guarantee we have the power to deliver.

Every model in our comprehensive, award-winning range of forklift trucks and warehouse equipment is built to a high specification and is designed to keep on working for you... day after day... year after year... whatever the job... whatever the conditions.

To ensure your truck stays in constant productive action, we have a network of local dealers – hand-picked for their commitment to customer care... and backed up by the Mitsubishi Forklift Trucks organisation. No matter where you are, we have a dealer close by – ready and willing to meet your needs.

That friendly local service covers everything from identifying the perfect model and configuration for your application to providing competitive, flexible finance and maintenance packages, unbeatable warranties, long and short term hire, and highly responsive field service and repairs... as well as the industry's quickest and most reliable parts supply.

Only Mitsubishi can give you this combination of global engineering excellence and outstanding local support... only Mitsubishi offers you such a quality product at such an affordable price... and only Mitsubishi places reliability as high as you do in its priorities. Contact your local dealer now and see what Mitsubishi can do for you.

You can find your nearest dealer at www.mitforklift.com



Integrated Presence System (IPS) provides:

- a hydraulic and travel interlock system that prevents all movement of the truck and its mast if the driver is not seated
- a seat belt warning light
- a parking brake alarm

The term 'Integrated Presence System' (IPS) is intended as a trading style, only to describe a number of design features on the Mitsubishi trucks to which IPS is applied. It does not imply that the truck can be driven without appropriate operator training and without due care and attention. The manufacturer (MCFE, Almere, the Netherlands) cannot accept any responsibility for any accidents or damage caused by incorrect or dangerous use of its equipment.



CESM1961 (03/19)
© 2019 MCFE
Printed in The Netherlands

mitforklift@mcf.nl www.mitforklift.com

NOTE: Performance specifications may vary depending on standard manufacturing tolerances, vehicle condition, types of tyres, floor or surface conditions, applications or operating environment. Trucks may be shown with non-standard options. Specific performance requirements and locally available configurations should be discussed with your distributor of Mitsubishi forklift trucks. Mitsubishi follows a policy of continual product improvement. For this reason, some materials, options and specifications could change without notice.